



***www.cignus.com.ph***



CIGENUS<sup>TM</sup>



# ***CG-818mini***

## **MOBILE RADIO**

# **USER'S MANUAL**



***Mobile Radio***

**CG-818MINI**

**Nice Housing, Stoutness & Stability, Advanced and Reliable functions, Perfect & Valuable. CG-818mini mobile radio especially designs for drivers and it pursues company philosophy of innovation and practicality.**



**NOTE** When programming the transceiver, read the factory initial data firstly, then rewrite the frequency and signaling etc., otherwise errors may occur because of different frequency band etc..

CG-818mini Mobile Radio Applicable Software: CG-818mini

Models Apply To This Manual: CG-818mini Mobile radio

# MOBILE RADIO

---

---

Thank you for choosing this CIGNUS vehicle transceiver, CIGNUS always provides high quality products, And this transceiver is no exception. As you learn how to use this transceiver, you will find that CIGNUS is pursuing "user friendliness". For example, each time you change the menu no. in Menu mode, you will see a text message on the display that lets you know what you are configuring.

Though friendly design for user, this transceiver is technically complicated and some features may be new to you. Consider this manual to be a personal tutorial from the designers, allow the manual to guide you through the learning process now, then act as a reference in the coming years.

## Precautions

Please observe the following precautions to prevent fire, personal injury, or transceiver damage:

- ⚠ Do not attempt to configure your transceiver while driving, it is dangerous.
- ⚠ This transceiver is designed for a 13.8V DC power supply. Don't use a 24V battery to power on the transceiver.
- ⚠ Do not place the transceiver in excessively dusty, humid or wet areas, nor unstable surfaces.
- ⚠ Please keep it away from interferential devices (such as TV, generator etc.).
- ⚠ Do not expose the transceiver to long periods of direct sunlight nor place it close to heating appliances.
- ⚠ If an abnormal odor or smoke is detected coming from the transceiver, turn OFF the power immediately. Contact an CIGNUS service station or your dealer.
- ⚠ Do not transmit with high output power for extended periods; the transceiver may overheat.

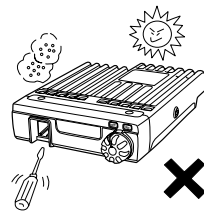



## SAFETY TRAINING INFORMATION

### WARNING:

This radio generates RF electromagnetic energy during transmission. This radio is designed for and classified as “Occupational Use Only”, meaning it must be used only during the course of employment by individuals aware of the hazards, and the ways to minimize such hazards. This radio is NOT intended for use by the “General Population” in an uncontrolled environment.

- For compliance with FCC and Industry Canada RF Exposure Requirements, the transmitter antenna installation shall comply with the following two conditions:

1. The transmitter antenna gain shall not exceed 0 dBi.
2. The antenna is required to be located outside of a vehicle and kept at a distance of 63 centimeters or more between the transmitting antenna of this device and any persons during operation. For small vehicle as worst case, the antenna shall be located on the roof top at any place on the centre line along the vehicle in order to achieve 63 centimeters separation distance. In order to ensure this distance is met, the installation of the antenna must be mounted at least 63 centimeters away from the nearest edge of the vehicle in order to protect against exposure to bystanders.

### CAUTION:

To ensure that your exposure to RF electromagnetic energy is within the FCC allowable limits for occupational use, always adhere to the following guidelines:

- DO NOT operate the radio without a proper antenna attached, as this may damage the radio and may also cause you to exceed FCC

RF exposure limits. A proper antenna is the antenna supplied with this radio by the manufacturer or an antenna specifically authorized by the manufacturer for use with this radio.

- DO NOT transmit for more than 50% during the time of employment (50% duty cycle or less). Transmitting excessive amount of time can cause RF exposure compliance requirements to be exceeded. Please carefully read this instruction manual to learn how to transmit and stop transmitting before starting to use it.

### Electromagnetic Interference/Compatibility

During transmissions, your radio generates RF energy that can possibly cause interference with other devices or systems. To avoid such interference, turn off the radio in areas where signs are posted to do so. DO NOT operate the transmitter in areas that are sensitive to electromagnetic radiation such as hospitals, aircraft, and blasting sites.

### Occupational/Controlled Use

This product is used in situations that users are exposed to RF as consequence of their employment provided those users are fully aware of the potential RF hazards and can exercise control over their exposure.

- This transceiver is NOT ATEX approved and NOT intended for the use in hazardous explosive atmospheres.

---

---

# CONTENTS

<b>New and Innovative Features</b> .....	1	transmitting audio signal .....	12
<b>Supplied Accessories/Optional Accessories</b> .....	2	Channel Edit .....	12
Supplied Accessories .....	2	Channel Delete .....	12
Optional Accessories .....	2	<b>Shortcut Operations</b> .....	13
<b>Initial Installation</b> .....	3	squelch off/squelch off momentARY .....	13
Mobile installation .....	3	Squelch level Setup .....	13
DC Power Cable Connection .....	3	Frequency/Channel Scan .....	13
Antenna Connection .....	5	Scan Skip .....	13
Accessories Connections.....	5	CTCSS/DCS Encode and Decode setup .....	13
<b>Getting Acquainted</b> .....	7	Channel Scan .....	14
microphone .....	7	DCS SCAN .....	14
Front panel.....	8	FM radio .....	14
Rear panel .....	8	Power level control.....	14
DISPLAY .....	9	Offset Direction and offset frequency setup .....	15
<b>WORKING MODE (AMATEUR TRANSCEIVER OR PROFESSIONAL TRANSCEIVER)</b> .....	10	KEYPAD LOCKOUT .....	15
<b>Basic Operations</b> .....	11	<b>Function Menu</b> .....	16
Switching The Power On/Off.....	11	Signaling Combination setup .....	16
Adjusting The Volume .....	11	HIGH/MID/LOW Power Selection .....	16
Switch between VFO and Channel mode.....	11	Band-width Selection .....	16
Adjusting Frequency/Channel.....	11	Busy Channel Lockout .....	16
Receiving .....	11	Roger Beep .....	17
Transmitting .....	11	Audio signaling call setup .....	17
Transmitting Tone-Pulse .....	12	Editing Channel NAME .....	17
Roger beep .....	12	TX OFF .....	17
		Reverse TX/RX.....	17

---



---

# CONTENTS

Talk Around .....	18
Frequency Step Sie Setup .....	18
Squelch Level Setup .....	18
Display mode setup .....	18
Apo Setup .....	18
Pilot Frequency .....	19
TOT(Time Out Timer).....	19
Scan Dwell Time Setup.....	19
MIC Gain Setup .....	19
LCD contrast ratio setup .....	19
Backlight color.....	19
backlight brightness .....	20
voice prompt setup.....	20
Automatic Power on.....	20
Reset Factory Default .....	20
<b>Programming Software Installing and Starting (in windows XP system)</b> .....	21
Install USB Cable Driver Programme .....	21
<b>Maintenance</b> .....	22
Default Setting after Resetting .....	22
Trouble Shooting.....	22
<b>Specifications</b> .....	23
<b>Attached Chart</b> .....	24
50 groups CTCSS Tone Frequency(Hz) .....	24
1024 groups DCS Code.....	24

CG-818mini Mobile Radio has nice housing, stoutness & stability, advanced and reliable functions, perfect & valuable. This amateur mobile radio especially designs for drivers and it pursues company philosophy of innovation and practicality. More functions as follows:

- ▼ Display on a large LCD with adjustable brightness, convenient for nighttime use.
- ▼ Amateur mode and professional mode for different operation requirement.
- ▼ Distribute buttons reasonably, convenient for operation.
- ▼ Adopt superior quality material, better technology and high quality radiator to ensure stable and durable operation.
- ▼ 512 programmable memory channels, identified by editing name.
- ▼ Separate CTCSS, DCS setting for each single channel, rejecting extra calling from other radios.
- ▼ Various scan functions including CTCSS/DCS Scan function.
- ▼ Separate band width setting for each single channel.
- ▼ Programmable RB/CALL function.
- ▼ ALL control and display by Microphone
- ▼ 3 backlight color LCD
- ▼ SQ/VOL/Voltage level display
- ▼ FM radio receiver
- ▼ Optional earphone(Item number: HS03)
- ▼ Optional remote control PTT cable (Item number: EK01)



### ■ SUPPLIED ACCESSORIES

After carefully unpacking the transceiver, identify the items listed in the table below. We suggest you keep the box and packaging.

- Transceiver



- Microphone



- Mobile Bracket

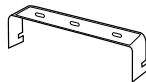

- DC Power Cable with Fuse Holder(QPL-01)



- Spare Fuses  
10A 250V [QF-02]



- Fixing pad



- User Manual



- Microphone Hanger



- Hardware Kit for Bracket

- Tapping screws



- S-Washer for radio



- Adjust knob



- S-Washer for hanger



- Tapping screws Microphone



### ■ OPTIONAL ACCESSORIES

- PC cable (PC55)



- Programming Software  
(CG-818mini)



- External Speaker  
(SP-01)



- Regulated Power  
Supply (QRP-01)



- Car Antenna  
(QCA-01)



## MOBILE INSTALLATION

To install the transceiver, select a safe, convenient location inside your vehicle that minimizes danger to your passengers and yourself while the vehicle is in motion. Consider installing the unit at an appropriate position so that knees or legs will not strike it during sudden braking of your vehicle. Try to pick a well ventilated location that is shielded from direct sunlight.

1. Install the mounting bracket in the vehicle using the supplied self-tapping screws (4pcs) and flat washers (4pcs).

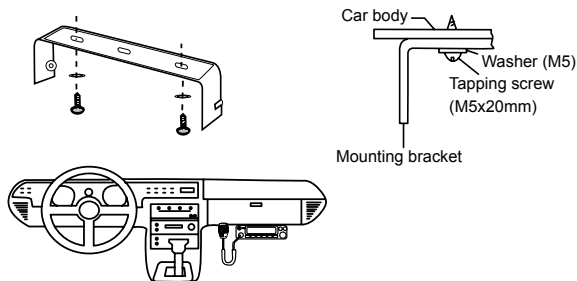

2. Position the transceiver, then insert and tighten the supplied hexagon SEMS screws.

- ▼ Double check that all screws are tightened to prevent vehicle vibration from loosening the bracket or transceiver.

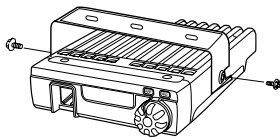

## DC POWER CABLE CONNECTION



Locate the power input connector as close to the transceiver as possible.

### MOBILE OPERATION

The vehicle battery must have a nominal rating of 12V. Never connect the transceiver to a 24V battery. Be sure to use a 12V vehicle battery that has sufficient current capacity. If the current to the transceiver is insufficient, the display may darken during transmission, or transmitting output power may drop excessively.

1. Route the DC power cable supplied with the transceiver directly to the vehicle's battery terminals using the shortest path from the transceiver.
  - ▼ We recommend you do not use the cigarette lighter socket as some cigarette lighter sockets introduce an unacceptable voltage drop.
  - ▼ The entire length of the cable must be dressed so it is isolated from heat, moisture, and the engine secondary (high voltage) ignition system/ cables.
2. After installing cable, in order to avoid the risk of damp, please use heat-resistant tap to tie together with fuse box. Don't forget to reinforce whole cable.
3. In order to avoid the risk of short circuit, please cut down connection with negative (-) of battery, then connect with radio.
4. Confirm the correct polarity of the connections, then attach the power cable to the battery terminals; red connects to the positive (+) terminal and black connects to the negative (-) terminal.
  - ▼ Use the full length of the cable without cutting off excess even if the cable is longer than required. In particular, never remove the fuse holders from the cable.

### 3 Initial Installation

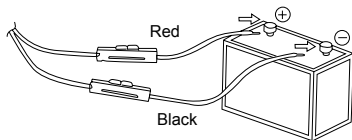

5. Reconnect any wiring removed from the negative terminal.
6. Connect the DC power cable to the transceiver's power supply connector.

▼ Press the connectors firmly together until the locking tab clicks

#### ✘ FIXED STATION OPERATION

In order to use this transceiver for fixed station operation, you will need a separate 13.8V DC power supply (not included), power supply( QRP-01) as optional accessories. Please contact local dealer to require.

The recommended current capacity of your power supply is 12A.

1. Connect the DC power cable to the regulated DC power supply and ensure that the polarities are correct. (Red: positive, Black: negative).
  - ▼ Do not directly connect the transceiver to an AC outlet.
  - ▼ Use the supplied DC power cable to connect the transceiver to a regulated power supply.
  - ▼ Do not substitute a cable with smaller gauge wires.

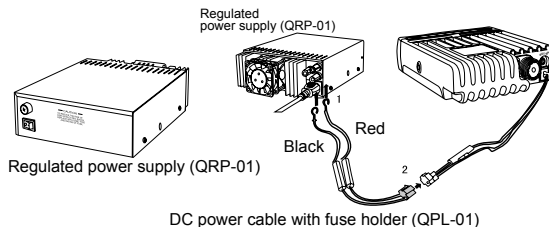

2. Connect the transceiver's DC power connector to the connector on the DC power cable.

▼ Press the connectors firmly together until the locking tab clicks.



- ▼ Before connecting the DC power to the transceiver, be sure to switch the transceiver and the DC power supply OFF.
- ▼ Do not plug the DC power supply into an AC outlet until you make all connections.

#### ✘ REPLACING FUSES

If the fuse blows, determine the cause, then correct the problem. After the problem is resolved, replace the fuse. If newly installed fuses continue to blow, disconnect the power cable and contact your autho-rized **CIGENUS** dealer or an authorized **CIGENUS** servicecenter for assistance.

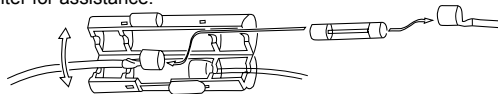

Fuse Location	Fuse Current Rating
Transceiver	10A
Supplied Accessory DC power cable	10A

Only use fuses of the specified type and rating, otherwise the transceiver could be damaged.



If you use the transceiver for a long period when the vehicle battery is not fully charged, or when the engine is OFF, the battery may become discharged, and will not have sufficient reserves to start the vehicle. Avoid using the transceiver in these conditions.

### ANTENNA CONNECTION

Before operating, install an efficient, well-tuned antenna. The success of your installation will depend largely on the type of antenna and its correct installation. The transceiver can give excellent results if the antenna system and its installation are given careful attention.

Use a  $50\Omega$  impedance antenna and low-loss coaxial feed-line that has a characteristic impedance of  $50\Omega$ , to match the transceiver input impedance. Coupling the antenna to the transceiver via feed-lines having an impedance other than  $50\Omega$  reduces the efficiency of the antenna system and can cause interference to nearby broadcast television receivers, radio receivers, and other electronic equipment.



Transmitting without first connecting an antenna or other matched load may damage the transceiver. Always connect the antenna to the transceiver before transmitting.

All fixed stations should be equipped with a lightning arrester to reduce the risk of fire, electric shock, and transceiver damage.

The possible locations of antenna on a car are shown as following:

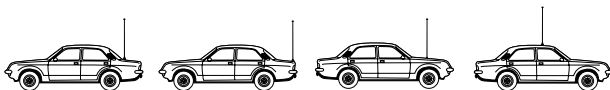

### ACCESSORIES CONNECTIONS

#### EXTERNAL SPEAKER

If you plan to use an external speaker, choose a speaker with an impedance of  $8\Omega$ . The external speaker jack accepts a 3.5mm (1/8") mono (2-conductor) plug.

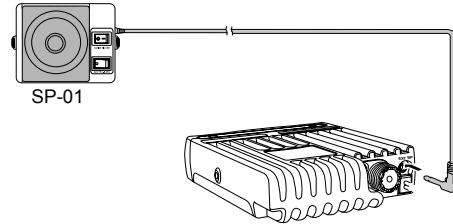

External speaker adopt double port BTL, please care about the connecting way. The speaker can not connect with the ground, otherwise the speaker will be fault. The wrong connecting way as the following picture.

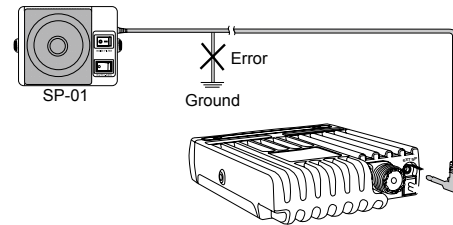

### 3 Initial Installation

#### ✘ MICROPHONE

Choose an suitable location to install the microphone hanger.

1. Use the microphone hanger to locate the position for the screws.
2. Use the screws and pads to fix the microphone hanger.

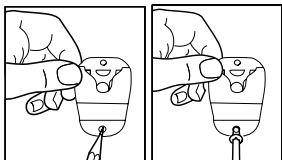

For voice communications, connect a microphone equipped with an 8-pin modular plug into the modular socket on the front of the main unit. Press irmly on the plug until the locking tab clicks.

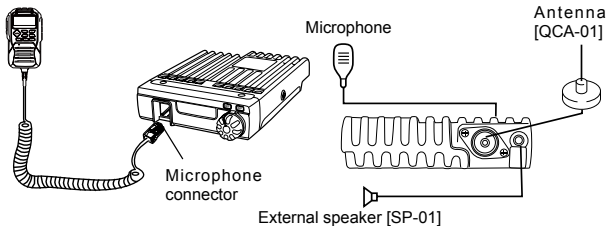

#### ✘ PC CONNECTING

To utilize the optional CG-818mini software, you must first connect the transceiver to your PC then using an optional programming cable PC55 (via Data socket ).

Please use CG-818mini software for programming.



NOTE Ask your dealer about purchasing a Programming Cable PC55.

## MICROPHONE

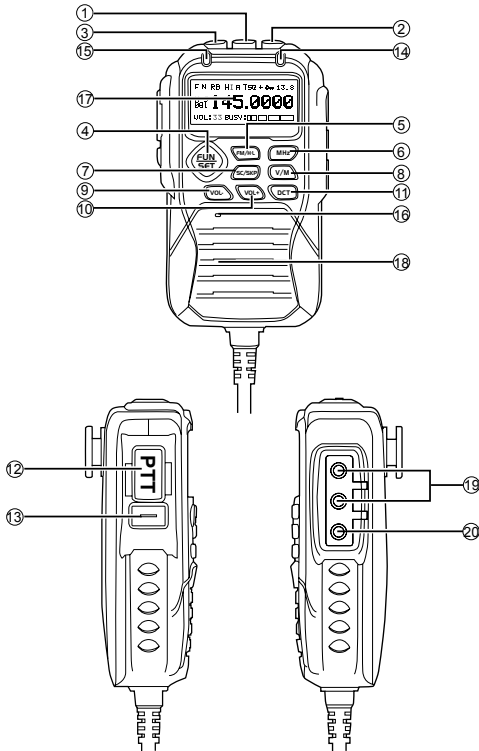

NO.	KEY	FUNCTION
1	POW	Power on/Off/Mute
2	UP	Increase frequency/channel/scan direction
3	DN	Reduce frequency/channel/scan direction
4	FUN/SET	Function Menu key
5	FM/H.L	FM radio/RF power switch key
6	MHZ	MHz step size Key
7	SC/SKP	Sscan delete/add key
8	V/M	VFO/Memory mode switch key
9	VOL-	Volume reduce key
10	VOL+	Volume increase key
11	DCT	CTCSS/DCS setting key
12	PTT	Transmit key
13	SQL	Squelch key
14	RX indicator	Light on when squelch valid
15	TX indicator	Light during transmitting
16	MIC	Speak into it during transmitting
17	LCD display	Display channel/frequency/function setting
18	Speaker	Listen to calls
19	Earphone Jack	Use for connect an optional earphone piece
20	Ex- PTT jack	Use for connect an optional PTT cable

## 4 Getting Acquainted

- Press **FUN/SET** key until  icon appears then press the following key.

NO.	KEY	FUNCTION
1	FM/H.L	RF Power level switch(HI/MI/LO)
2	MHz	Off set frequency and direction setting.
3	SC/SKP	Channel scan delete or add.
4	V/M	Channel store
5	VOL-	Fast reduce volume level by 10 steps/push
6	VOL+	Fast increase volume level by 10 steps/push
7	DCT	Keypad lock

- Hold **FUN/SET** key then press the following keys:

NO.	KEY	FUNCTION
1	MHz	Wide/Narrow band switch
2	V/M	Delete memory channel

- Hold the following keys:

NO.	KEY	FUNCTION
1	FUN/SET	Enter setting mode after hold it for 2 seconds
2	SQL	Turn on Monitor

### Microphone connector pins(Front view)

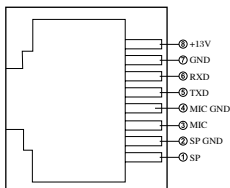

### FRONT PANEL

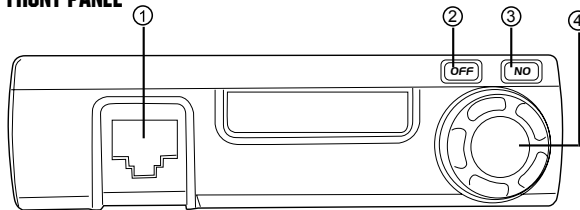

NO.	LTEM	FUNCTION
1	Microphone jack	Microphone jack
2	Power Off indicator	Light on when power off
3	Power On indicator	Light on when power on
4	Power On/Off knob	Power On/ Off the transceiver

### REAR PANEL

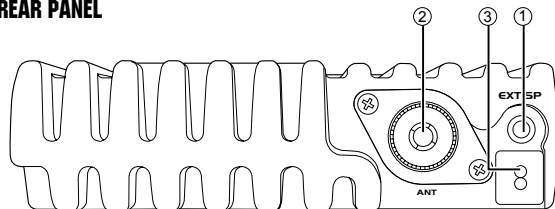

NO.	LTEM	FUNCTION
1	Antenna connector	Connect a 50 ohm antenna
2	Ex - Speaker Jack	Connect optional SP-01 external speaker
3	Power cable	Connect optional SP-01 external speaker Connect a standard DC power cable

## ■ DISPLAY

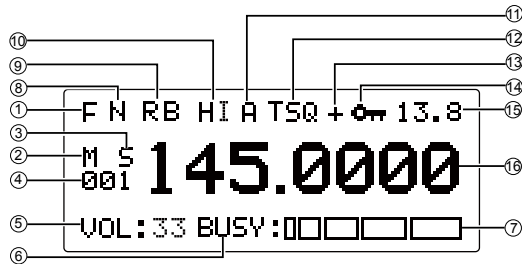

NO.	LCON	FUNCTION
1	F	Displays when press FUN/SET key
2	M	Displays in memory mode
3	S	Displays when Scan function on
4	001	Display memory channel number in memory mode
5	VOL: 33	Displays when setting VOL/SQ level
6	BUSY	Displays during receiving or when Monitor is ON
7	[ ] [ ] [ ] [ ]	Displays signal strength
8	N	Displays when setting band width
9	RB	Displays when sending RB/TB/CL
10	HI	Displays H/M/L power level setting
11	A	Displays when Automatic power off function on
12	TSQ	Displays when setting CTCSS/DCS

13	+	Display when setting offset direction
14	Off	Displays when key lock function on
15	13.8	Displays current voltage level
16	145.0000	Displays frequency or memory channel name



## 5 WORKING MODE (AMATEUR TRANSCEIVER OR PROFESSIONAL TRANSCEIVER)

According to practical application, you can set the radio works as Amateur Transceiver mode or Professional Transceiver mode. There are also 2 levels operation menu to set functions as you need. It is easy and convenient (From No.1 to No. 10 are channel function setup, From No.11 to No.24 are general setting setup).

### 1. Working Mode:

**A. By programming software:** In PC software's "General Setting" menu, choose "Display Mode" to select Amateur Transceiver mode or Professional Transceiver mode.

**B. BA By manual setup:** Please refer to "Display Mode" in Page 11.

2. **Amateur Transceiver Mode:** Except setting as "CH" mode, others considered as Amateur transceiver mode. Under this mode, press  key to switch between Channel mode and VFO mode.

**A. Frequency + Channel mode:** When set display as "FR", it enters into Frequency+Channel mode, new setting of channel operation and shortcut operation can be temporarily used by user. Once the radio is turned off or switched to another channel, the temporary setting will be erased and back to initial settings. (As pic 1)

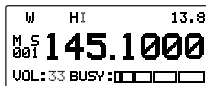

(Pic 1)

**B. Channel+Name Tag Mode:** When set display as "NM", it enters into Channel +Name Tag mode. At this mode, it will display corresponding channel name when the current channel is edited with name. Otherwise, it will display frequency + channel. Its operations are the same as frequency + channel mode. (As pic 2)



(Pic 2)

### C. VFO Mode(Frequency mode):

This mode shows only frequency on the display. Shortcut operation and Channel setting will be changed & stored as the latest value permanently. Once the radio is turned off or changed to new VFO frequency, the latest setting is remained until next change. (As pic 3)



(Pic 3)

3. **Professional Transceiver Mode:** When set display mode as "CH", it enters into Professional Transceiver mode. At this mode, except scan, other shortcut operation can't operate. And from No.1-10 menu in function setting will be auto-hidden, They should be set by PC software. If there is corresponding name for current channel, the LCD will display current channel name. Otherwise, it shows current channel number. (As Pic 4 and Pic 5)



(Pic 4)



(Pic 5)

 **NOTE** If transceiver programmed as professional transceiver mode and locked, you can't return to amateur transceiver mode by manual operation from general setting.

4. Under every mode, from No. 11-24 menu in general setting can be changed and saved.

## SWITCHING THE POWER ON/OFF

1. When the transceiver in power off, turn clockwise the power on/off knob, the indicator lights green then the transceiver is power on.
2. When the transceiver in power on, turn anticlockwise the power on/off knob, the indicator lights red then the transceiver is power off.
3. When the transceiver in power on, can press **POW** for over 2 seconds to power off, and then short press **POW** to power on.

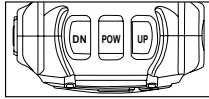

## ADJUSTING THE VOLUME

1. Short press **VOL+** or **VOL-** to increase or decrease volume by one step. Hold **VOL+** or **VOL-** to fast increase or decrease volume. Short press **FM/STEP** and or to increase **VOL+** or **VOL-** decrease volume by 10 steps.
2. During receiving, press **POW** to temporary mute the speaker, the LCD displays VOL:MT, press any key to exit mute mode.

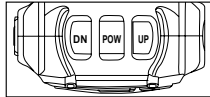

**NOTE** During communication, volume level can be adjusted more accurate.

## SWITCH BETWEEN VFO AND CHANNEL MODE

In standby, press **V/M** until LCD appears M. This indicates the radio is in channel mode. Repeat above operation to switch between frequency mode(VFO) and channel mode.

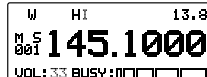

## ADJUSTING FREQUENCY/CHANNEL

1. In frequency mode, Short press **UP** or **DN** to increase or decrease frequency by one step size. Hold **UP** or **DN** to

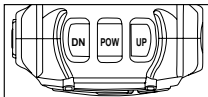

fast increase or decrease frequency. Short press **MHz**, the MHz will flash, hold **UP** or **DN** will change the frequency move by 1 MHz step size. press any key to exit this mode.

**NOTE** 2.5K,5K, 6.25K, 10K, 12.5K, 20K, 25K, 30K and 50K total nine step size available for this radio.

2. In channel mode, short press **UP** or **DN** to increase or reduce channel by one step. Hold **UP** or **DN** to fast increase or reduce channel. Short press **MHz**, the channel number flashes, then press **UP** or **DN** to increase or reduce channel by 10 steps. Hold **UP** or **DN** to fast increase or decrease channel at 10 steps speed, press any key to exit.

## RECEIVING

When the channel you are operating being called, the screen shows BUSY, and field strength. in this way you can hear the calling.

**NOTE** If the transceiver has set at higher squelch level, it may fail to hear the calling.

When the radio screen shows BUSY, field strength and green LED indicator flashes, but can not hear the calling, it means current channel receive a matching carrier but unmatching signaling. (Refer to CTCSS/DCS CODE or Optional Signaling setup in Page 13)

## TRANSMITTING

Hold **PTT** to monitor for a while, to confirm the current channel is not busy, then release. Hold PTT key and speaker into microphone. Hold **PTT** the microphone approximately 2.5-5.0cm from your lips and speak into the microphone in your normal speaking voice to get best timbre.

Hold PTT key, the LED lights red and power strength show in the screen, NOTE indicates it is transmitting, release PTT to receive.

### TRANSMITTING TONE-PULSE

Hold PTT key, then press microphone **DN** key to transmit selected tone-pulse signal, the LCD displays TB.

W	TB	HI	13.8
M	S	001	145.0000
VOL: 33		PWR: ■■■■■■	

### ROGER BEEP

After release the PTT key, the radio will automatic transmit pro-stored RB, the LCD displays RB.

W	RB	HI	13.8
M	S	001	145.0000
VOL: 33		PWR: ■■■■■■	

### TRANSMITTING AUDIO SIGNAL

Hold PTT key, then press microphone **UP** key to transmit pre-stored audio signal, the the LCD displays CL.

W	CL	HI	13.8
M	S	001	145.0000
VOL: 33		PWR: ■■■■■■	

### CHANNEL EDIT

- In VFO mode, press **UP** / **DN** or **MHz** to choose wanted frequency.
- Press **OCT** key to enter CTCSS/DCS setup. Press **UP** / **DN** to select the signaling.
- Enter channel menu No 1-10 and choose related setup.
- Press **FUNC** key, the LCD displays **F**, if the **M** icon not flash means current channel number is valid. If M icon flashes means current

W	HI	13.8
UFD	145.0000	
VOL: 33		BUSY: □□□□□□

W	HI	TSQ	13.8
UFD	145.0000		
VOL: 33		BUSY: □□□□□□	

channel number is empty.

- Press **UP** / **DN** key choose wanted channel number.
- Press **V/M** key store the channel, the **F** icon disappear, the **M** icon and channel number no flash and emit a prompt, it means the channel stored success.

F	W	HI	TSQ	13.8
M	018	145.0000		
VOL: 33		BUSY: □□□□□□		

### CHANNEL DELETE

- In channel mode, press **UP** / **DN** to choose a unwanted channel.
- Hold **FUNC** and **V/M** key for over 1 second, the current channel will be deleted. the radio emit a prompt and jump to next working channel.

## ■ SQUELCH OFF/SQUELCH OFF MOMENTARY

key programmed as Squelch Off or Squelch Off Momentary to monitor the weak signal.

1. Squelch Off: Press key to disable squelch, press key again to resume squelch.
2. Squelch Off Momentary: Press and hold key to disable squelch, release key to resume squelch.



NOTE The above functions should be set in programme software.

## ■ SQUELCH LEVEL SETUP

This function use for setting RX signal strength, the calling will be heard only when reach setted level, otherwise the radio will keep mute.

1. In standby, hold key, then press or key, the LCD displays current squelch level.
2. Press or key to choose wanted squelch level.
3. Press any key to confirm and exit.



## ■ FREQUENCY/CHANNEL SCAN

### ✕ FREQUENCY SCAN

In frequency (VFO) mode, this function is designed to monitor signal of all frequency points under each step size.

1. In VFO mode, press to start frequency scan.
2. Press or to change scan direction.
3. Press any key except / or key to exit scan.



### ✕ CHANNEL SCAN

In channel mode, this function is used to monitor signal in all channels.

1. In channel mode, Press key start channel scan.
2. Press or to change scan direction.
3. Press any key except / or key to exit scan.



## ■ SCAN SKIP

In channel mode, press and then press key to add or delete a scan channel.

1. When the left side of the LCD displays "S", the current channel added to scan list. this channel will be scanned when scan function start.
2. When the "S" disappears, the current channel is deleted from scan list. this channel will not be scanned when start scan function.

## ■ CTCSS/DCS ENCODE AND DECODE SETUP

Repeaterly press key, to set CTCSS/DCS encode/decode for current channel.

1. When the LCD displays TSQ, means current channel set with CTCSS code, press or to choose wanted code.
2. When the LCD displays DCS, means current channel set with DCS code, press or to choose wanted code.
3. CTCSS code: 62.5-254.1 total 51 groups

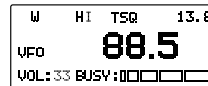

## 7 Shortcut Operations

DCS code: 000N-777I total 1024 groups, N is positive code, I is inverse code. Press to choose positive code or inverse code.



4. Press any key except , , or key to exit scan.

Under channel mode, this operation can be temporarily used by user. Once the radio is turned off or switched to another channel, the temporary setting will be erased. If the channel setting programmed for valid, the temporary setting will keep valid until next change, turn off radio or switch to another channel, the temporary setting will not be changed.

NOTE

### CHANNEL SCAN

Repeatedly press until LCD displays TSQ. Press to enter CTCSS scan mode. Once finding a matching CTCSS signaling, it will stop for 15S then scan again. Press any key exit.

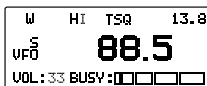

### DCS SCAN

Repeatedly press until LCD displays TSQ. Press to enter CTCSS scan mode. Once finding a matching CTCSS signaling, it will stop for 15S then scan again. Press any key exit.



### FM RADIO

Press to switch between FM radio and two way radio mode.



In FM radio mode:

1. Press to switch between frequency mode and channel mode.
2. Press / / to change frequency or channels. (Refer to page 11, Adjusting Frequency/Channel)
3. Press to start FM radio frequency or channel scan. (page 13, Frequency/Channel Scan)
4. Press and to store or delete a channel. (Refer to page 12, Channel Edit/ Channel Delete)
5. Press or to adjust volume level. (Refer to page 11, Adjusting The Volume)
6. In FM radio mode, you can setup resume method when radio receive any valid radio signal)

A. Press , the LCD displays S, when receiving valid radio signaling, the LCD displays radio interface but the FM radio still on.



B. Press , the S disappears from the LCD, when receiving valid radio signaling, the radio will exit FM radio mode and switch to radio interface.

NOTE FM radio adjusting step size is 50Khz, and scan step size is 100Khz.

### POWER LEVEL CONTROL

Press then press to switch among high, middle, low power level, the LCD displays current power level.

Displays **HI**: transmit by high power level.

Displays **MI**: transmit by middle power level.



Displays **LO**: transmit by low power level.



## ■ OFFSET DIRECTION AND OFFSET FREQUENCY SETUP

Repeater receives a signal(UP-LINK) on one frequency and retransmits on another frequency(DOWN-LINK). The difference between these two frequencies is called the offset frequency. If the UP-LINK frequency higher than DOWN-LINK frequency, the direction is positive, If it is lower, the shift direction is negative.

1. Press then press . the LCD displays the offset direction and offset frequency.

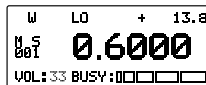

2. Repeatedly press key to choose positive or negative offset.

3. When the LCD display "+" Icon, it indicates positive offset, the transmitting frequency is higher than receiving frequency.



4. When the LCD display "-" Icon, it indicates negative offset, the receiving frequency is higher than transmitting frequency.

5. Press to change offset frequency. offset frequency change as per step size setting.





6. Press any key except , , key to exit.

## ■ KEYPAD LOCKOUT

Avoiding unintentional operation, this function will lock the keys except [PTT] , , .



1. Press then press , the LCD displays , means the keypad is locked.
2. Repeater above operation, disappears, means the keypad is unlocked.

1. Hold  key for over 2S to enter function menu.
2. Press  or  key to choose menu list.
3. Press  or  key to choose wanted value.
4. Press any key to store and exit.



There are 2 part of function menu: part 1, Menu No. 1-10 channel function menu. part 2 Menu No. 11-24 function menu. Part 1 will automatically hide in channel mode. In FM radio receiver mode, it is invalid to enter function menu.

### ■ SIGNALING COMBINATION SETUP

Enter No. 01 function menu , the LCD displays "**KP:SQ**".This function can improve the level of blocking irrelative signals.

**SQ:**You can hear the calling when receive a mathcing carrier.

**CTC:**You can hear the calling when receive a mathcing carrrier and CTCSS/DCS signaling .  
Default:SQ

MENU:01

SPK : SQ

MENU:01

SPK : CTC



This setting is valid only when CTCSS/DCS signaling added.

### ■ HIGH/MID/LOW POWER SELECTION

Enter No. 02 function menu , the LCD displays "**POW:HI**".

This function use to control transmit power level.

MENU:02

POW : HI

**HI:**Transmit with high power.

**MI:**Transmit with middle power.

**LO:**Transmit with low power.

Default:HI

MENU:02

POW : MI

MENU:02

POW : LOW

MENU:03

BAND : 25

MENU:03

BAND : 20

MENU:03

BAND : 12

### ■ BAND-WIDTH SELECTION

Enter No 03 function menu , the LCD displays "**BNAD:25**".

Select suitable bandwidth in accordance with different local conditions

**25:** band width is 25k(Wide band)

**20:** band width is 20k(Middle band)

**12:** band width is 12.5k(Narrow band)

Default:25

### ■ BUSY CHANNEL LOCKOUT

Enter No 04. function menu , the LCD displays "**BUSY:OF**".

BCLO is to disable transmitting while RX signal is received. Once the channel is busy and you press PTT, the radio will beep as warning and get back to receiving.

**BU:** Enable BCLO, Carrier lockout, trans-mitting is inhibited when current channel receives a matching carrier; press [PTT] to emit error voice prompt and back to receiving status.

MENU:04

BUSY : OF

MENU:04

BUSY : BU

PL: Enable BTLO, transmitting is inhibited when current channel receives a matching carrier but dis-matching CTCSS/DCS. press.

OFF:BCLO is disabled.It can transmit in any receiving status.

Default: OFF

MENU:04

BUSY : RL

### ROGER BEEP

Enter No.05 function menu , the LCD displays "**RB:OFF**".

When release PTT to finish a calling, the radio will automatically transmit a remind beep sound to the receiver. This fucntion can avoid misunderstanding

when the caller pause speak but still hold PTT, and communciation will not full transmitted when the receiver also press PTT.

1-8: group RB sound available.

OFF: Turn off RB function.

Default: OFF

MENU:05

RB : OFF

### AUDIO SIGNALING CALL SETUP

Enter No.06 function menu , the LCD displays"**CAL:OFF**"

Hold PTT then press UP to transmit pre-programmed audio signaling, to check if the receiver is near the radio. and not necessary to speak into microphone to confirm.

1-8: group audio sound available.

OFF: Turn off RB function.

Default: OFF

MENU:06

CAL : OFF

### EDITING CHANNEL NAME

Enter No.07 function menu , the LCD displays.

1. Press **UP** or **DN** key to choose characater for present cursor ocaion.
2. Press **V/M** key to confirm and move to next characater edit.
3. Press **DCT** to return to last characater edit.

MENU:07

O\_



In Frequency (VFO) mode ,this function will be auto-hidden.

### TX OFF

Enter No.08 function menu , the LCD displays:

**"TX:ON"**.

This function use to disable the transmitting for current channel.

ON: TX allowed, press PTT to transmit.

OFF: TX not allowed, press PTT will emit a wrong report.

Default: ON

MENU:08

TX : OFF

MENU:08

TX : ON

### REVERSE TX/RX

Enter No.09 function menu , the LCD display "**REV:OFF**".

When turn of this function, the TX frequency turns to RX frequency & RX frequency changes to TX frequency. The signaling will reversed if CTCSS/DCS signaling exited in this channel.

MENU:09

REV : OFF



Default: ON

**ON:** Turn on reverse function

**OFF:** Turn off reverse function

MENU: 09  
**REV: ON**

### TALK AROUND

Enter No.10 function menu , the LCD displays "TALK:OF".

This function enable direct communication with other radios in case the repeater is not activated or when out of the repeater range. The transceiver will transmit by RX frequency with its CTCSS/DCS signaling.

Default: off

**ON:** Turn on talk around function

**OFF:** Turn off talk around function

MENU: 10  
**TALK: OF**

MENU: 10  
**TALK: ON**

### FREQUENCY STEP SIE SETUP

Enter No.11 function menu , the LCD displays "STP:12.5".

This function valid only in frequency (VFO) mode, input frequency or frequency scanning all restricted by frequency step size.

Total 9 Channel step size available: 2.5K,5K, 6.25K,10K,12.5K,20K,25K, 30K and 50K.

VHF Default: 12.5K

UHF Default: 25K

MENU: 11  
**STP: 12.5**



NOTE This function is auto-hidden in channel mode.

### SQUELCH LEVEL SETUP

Enter No.12 function menu , the LCD displays "SQL:03".

This function use for setting RX signal strength, the calling will be heard only when reach setted level, otherwise the radio will keep mute.

Default: 03

**OFF-09:** Total 10 levels OFF is lowest value(Open)

MENU: 12  
**SQL: 03**



NOTE

If the transceiver has set at higher squelch level,it may fail to hear the calling. If set at lower squelch level,the radio will be interfered.

### DISPLAY MODE SETUP

Enter No.13 function menu , the LCD displays "DSP:CH".

This radio has 3 different display modes: Frequency+Channel mode. Channel mode, Channel+Name Tag mode.

**FR:** Frequency+Channel mode

**CH:** Channel mode

**NM:** Channel+Name Tag mode(Amateur transceiver mode),if channel not named,it displays Frequency+Channel mode.

Default: FR

MENU: 13  
**DSP: FR**

MENU: 13  
**DSP: CH**

MENU: 13  
**DSP: NM**

### APO SETUP

Enter No.14 function menu , the LCD displays "APO: OFF".

Once APO is activated, the radio will be automatically switched off when the pre-set timer is running to end.

**30:** Auto power off after 30m  
**60:** Auto power off after 1h  
**120:** Auto power off after 2h  
**OFF:** Disable Auto power off  
 Default: OFF

MENU: 14  
**APO: OFF**

### PILOT FREQUENCY

Enter No.15 function menu , the LCD displays "**TB: 1750**".  
 This function uses to start repeater .It needs a certain intensity Pilot Frequency to start dormant repeater.As usual,no need to send pilot frequency again once repeater started.

**1000:** Pilot frequency 1000Hz  
**2100:** Pilot frequency 2100Hz  
**1450:** Pilot frequency 1450Hz  
**1750:** Pilot frequency 1750Hz  
 Default: 1750Hz

MENU: 15  
**TB: 1750**

### TOT(TIME OUT TIMER)

Enter No.16 function menu , the LCD displays "**TOT: 3**".  
 The time-out timer limits continuous transmitting time. When transmit time last over programmed value, the transmitting will stop and emit a prompt.

**1-30:** 1-30 minutes range available by 1 minute/step  
**OFF:** Turn off TOT function.  
 Default level: 1

MENU: 16  
**TOT: 3**

### SCAN DWELL TIME SETUP

Enter No.17 function menu , the LCD displays :"**SCAN: TO**".

MENU: 17  
**SCAN: TO**

This ardio has 3 kinds of Scan Dwell Time way.

**TO:** It pauses 15s once scanning a matching signal,then resume scan.

**CO:** It pauses once scanning a matching signal, signal disappeared then resume scan.

**SE:** It stops once scanning a matching signal.

Default: TO

MENU: 17  
**SCAN: CO**

MENU: 17  
**SCAN: SE**

### MIC GAIN SETUP

Enter No.18 function menu , the LCD displays "**MIG: 7**".

**1-16:** Total 16 levels available.

Default level: 7

MENU: 18  
**MIG: 7**

### LCD CONTRAST RATIO SETUP

EEEnter No.19 function menu , the LCD displays "**BRI:10**".

**1-30:** Total 4 level backlight available.

Default level: 10

MENU: 19  
**BRI: 10**

### BACKLIGHT COLOR

EEEnter No.20 function menu , the LCD displays "**COL:OR**".

This radio has 3 backlight colors:

**OR:** Orange

MENU:20  
**COL: OR**

MENU:20  
**COL: BL**

**BL:** BLue  
**PI:** Purple  
 Default: OR

MENU:20  
**COL:PI**

### ■ RESET FACTORY DEFAULT

Enter No.24 function menu , the LCD displays "RESTORE".

If your radio seems to be malfunctioning, resetting the microprocessor may solve the problem.

**FACT:** All channel, signaling function setup resume factory default.

**SETUP:** No.11-24 function menu setup resume factory default.

MENU:24  
**RESTORE**

MENU:24  
**FACT**

MENU:24  
**SETUP**

### ■ BACKLIGHT BRIGHTNESS

Enter No.21 function menu , the LCD displays "DIM: 3".

**OFF-3:** Total 4 level backlight available.  
**OFF:** Turn off backlight.  
 Default level: 3

MENU:21  
**DIM: 3**

### ■ VOICE PROMPT SETUP

Enter No.22 function menu , the LCD displays "BEEP:5".

The prompting tone provides confirmation of entry, error status or malfunctions of the transceiver.

**OF-5:** Total 6 groups available.  
**OF:** Turn off Voice prompt function  
 Default groups: 5

MENU:22  
**BEEP: 5**

### ■ AUTOMATIC POWER ON

Enter No.23 function menu , the LCD displays "AOP: ON".

When this function is off, the radio will not power on when connect power supply by turn power [On/Off] knob, user need press MIC **POW** key.

**ON:** Automatic power on function is on  
**OFF:** Automatic power on function is off  
 Default: ON

MENU:23  
**AOP: ON**

MENU:23  
**AOP: OFF**

Double click "CG-818mini-Setup.exe", then follow the installing instruction.

### ■ INSTALL USB CABLE DRIVER PROGRAMME

1. Click start menu in computer, under "ALL PROGRAMS" menu, choose and click "USB To Com port" in CG-818mini program, install "USB To Com port" driver by indication.
2. Connect the optional PC55 USB Programming cable to USB port in PC with transceiver.
3. Double click CG-818mini shortcut or click CG-818mini in procedure index of start menu, choose serial com port as indicated then click OK to start programming software.
4. According to instruction,select correct"COM Port, then click "OK" to start programming software.

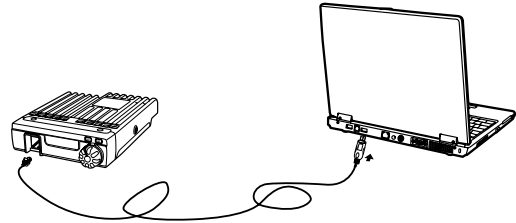

**NOTE** Even in same computer,the selective COM Port is different when USB cable connects with different USB port.

You shall install software before connecting the USB cable line. Switch on transceiver before writing frequency.You had better not switch on or off the power supply of transceiver when it is connected with computer, otherwise, it will make transceiver unable to read or write frequency. In this case, you have to turn off programming software, pull out USB cable. then reinsert USB cable and open software, then rechoose COM Port, it will turn into normal operation. Therefore, please connect transceiver with computer after switching on the transceiver. Don't restart transceiver power when it is connected with computer.

# 10 Maintenance

## DEFAULT SETTING AFTER RESETTNG

CG-818mini		
Frequency band	VHF	UHF
VFO frequency	145.000MHz	435.000MHz
Memory channel 0-512	CH1: 145.000MHz	CH1: 435.000MHz
Offset direction	--	--
Offset frequency	600KHz	5MHz
Channel step	12.5KHz	25KHz
CTCSS encode and decode	--	--
CTCSS tone frequency	88.5Hz	88.5Hz
DCS encode and decode	--	--
DCS Code	023N	023N
Output power	HI	HI
TOT	3	3
Squelch Level	3	3

## TROUBLE SHOOTING

Problem	Possible Causes and Potential Solutions
(a) Power is on, nothing appears on Display.	+ and - polarities of power connection are reversed. Connect red lead to plus terminal and black lead to minus terminal of DC power supply.
(b) Fuse is blown.	Check and solve problem resulting in blown fuse and replace fuse with new fuse.
(c) Display is too dim.	Dimmer setting is "LAMP-L". Please make the dimmer setting "LAMP-H".
(d) No sound comes from speaker.	<ul style="list-style-type: none"><li>• Squelch is muted. Decrease squelch level.</li><li>• Tone or CTCSS/DCS squelch is active. Turn CTCSS or DCS squelch off.</li></ul>
(e) Key and Dial do not function.	Key-lock function is activated. Cancel Key-lock function.
(i) Rotating Dial will not change memory channel.	Transceiver is in CALL mode. Press the VFO or memory mode.
(g) PTT key is pressed but transmission does not occur.	<ul style="list-style-type: none"><li>• Microphone connection is poor. Connect microphone properly.</li><li>• Antenna connection is poor. Connect antenna properly.</li></ul>

## General

Frequency Range	VHF: 136-174MHz UHF: 400~490MHz
Number of Channels	512 channels
Channel Spacing	25K (Wide Band) 20K(Middle Band) 12.5K (Narrow band)
Phase-locked Step	5KHz, 6.25KHz, 8.33KHz, 10KHz, 12.5KHz, 20KHz, 25KHz, 30KHz, 50KHz
Operating Voltage	13.8V DC $\pm 15\%$
Squelch	Carrier/CTCSS/DCS
Frequency Stability	$\pm 5$ ppm
Operating Temperature	-20°C~+60°C
Dimensions(WxHxD)	112 (W) x 30(H) x 14.2 (L)mm
Weight	about 0.51Kg

 Specifications are subject to change without notice due to advancements in NOTE technology.

## Receiver (ETSI EN 300 086 standard testing )

	Wide band	Narrow band
Sensitivity (12dB Sinad)	$\leq 0.25\mu V$	$\leq 0.35\mu V$
Adjacent Channel Selectivity	$\geq 60$ dB	$\geq 60$ dB
Audio Response	+1~-3dB(0.3~3KHz)	+1~-3dB(0.3~2.55KHz)
Hum & Noise	$\geq 45$ dB	$\geq 40$ dB
Audio distortion	$\leq 5\%$	
Audio power output	$> 2W@8\Omega$	

## Transmitter (ETSI EN 300 086 standard testing )

	Wide band	Narrow band
Power Output	25W / 15W / 5W	
Modulation	16KΦF3E	11KΦF3E
Adjacent Channel Power	$\geq 70$ dB	$\geq 60$ dB
Hum & Noise	$\geq 40$ dB	$\geq 36$ dB
Spurious Emission	$\geq 60$ dB	$\geq 60$ dB
Audio Response	+1~-3dB(0.3~3KHz)	+1~-3dB(0.3~2.55KHz)
Audio Distortion	$\leq 5\%$	

## 12 Attached Chart

### 50 GROUPS CTCSS TONE FREQUENCY(HZ)

1	62.5	12	94.8	23	136.5	34	177.3	45	218.1
2	67.0	13	97.4	24	141.3	35	179.9	46	225.7
3	69.3	14	100.0	25	146.2	36	183.5	47	229.1
4	71.9	15	103.5	26	151.4	37	186.2	48	233.6
5	74.4	16	107.2	27	156.7	38	189.9	49	241.8
6	77.0	17	110.9	28	159.8	39	192.8	50	250.3
7	79.7	18	114.8	29	162.2	40	196.6	51	254.1
8	82.5	19	118.8	30	165.5	41	199.5		
9	85.4	20	123.0	31	167.9	42	203.5		
10	88.5	21	127.3	32	171.3	43	206.5		
11	91.5	22	131.8	33	173.8	44	210.7		

### 1024 GROUPS DCS CODE.

000	001	002	003	004	005	006	007
010	011	012	013	014	015	016	017
020	021	022	023	024	025	026	027
030	031	032	033	034	035	036	037
040	041	042	043	044	045	046	047
050	051	052	053	054	055	056	057
060	061	062	063	064	065	066	067
070	071	072	073	074	075	076	077
100	101	102	103	104	105	106	107
110	111	112	113	114	115	116	117
120	121	122	123	124	125	126	127
130	131	132	133	134	135	136	137
140	141	142	143	144	145	146	147
150	151	152	153	154	155	156	157
160	161	162	163	164	165	166	167
170	171	172	173	174	175	176	177
200	201	202	203	204	205	206	207
210	211	212	213	214	215	216	217
220	221	222	223	224	225	226	227
230	231	232	233	234	235	236	237
240	241	242	243	244	245	246	247
250	251	252	253	254	255	256	257
260	261	262	263	264	265	266	267
270	271	272	273	274	275	276	277
300	301	302	303	304	305	306	307
310	311	312	313	314	315	316	317
320	321	322	323	324	325	326	327
330	331	332	333	334	335	336	337

340	341	342	343	344	345	346	347
350	351	352	353	354	355	356	357
360	361	362	363	364	365	366	367
370	371	372	373	374	375	376	377
400	401	402	403	404	405	406	407
410	411	412	413	414	415	416	417
420	421	422	423	424	425	426	427
430	431	432	433	434	435	436	437
440	441	442	443	444	445	446	447
450	451	452	453	454	455	456	457
460	461	462	463	464	465	466	467
470	471	472	473	474	475	476	477
500	501	502	503	504	505	506	507
510	511	512	513	514	515	516	517
520	521	522	523	524	525	526	527
530	531	532	533	534	535	536	537
540	541	542	543	544	545	546	547
550	551	552	553	554	555	556	557
560	561	562	563	564	565	566	567
570	571	572	573	574	575	576	577
600	601	602	603	604	605	606	607
610	611	612	613	614	615	616	617
620	621	622	623	624	625	626	627
630	631	632	633	634	635	636	637
640	641	642	643	644	645	646	647
650	651	652	653	654	655	656	657
660	661	662	663	664	665	666	667
670	671	672	673	674	675	676	677
700	701	702	703	704	705	706	707
710	711	712	713	714	715	716	717

720	721	722	723	724	725	726	727
730	731	732	733	734	735	736	737
740	741	742	743	744	745	746	747
750	751	752	753	754	755	756	757
760	761	762	763	764	765	766	767
770	771	772	773	774	775	776	777

 **NOTE** N is positive code, I is negative code, total: 232 groups.